

DO YOU NEED TO

BUST

SOME

NUTS?



BUSTIN' YOUR NUTS
INDUSTRIALBOLTING
888-925-3284

Industrial Bolting had its humble beginnings in 1999 in Central Indiana after seeing a need for a more diversified company to offer a wide range of tools. A place for customers to call and acquire all their tools in one spot, saving them time and money.

We have offered the best torque and tension products to our customers in the Plastic, Refining, Power, Mining, Wind, Heavy Equipment and Pipeline businesses. We have offered 24/7 – 365-day service for nearly 20 years, always expanding our fleet to meet the heavy demands of today’s bolting world.

We do not turn our business off after 5pm or holidays. We will respond faster, more knowledgeable and have tooling on the ground headed your way in minutes, not hours.

We have the largest torque/tension inventory within 1000 miles of Indiana. Our “no sales quota” sales reps are not pushy and will offer you multiple options to your bolting needs, instead of just being forced to sell one product. We use all of our resources to find the best fit for our customers.

We want to earn your business, let us prove to you that we are the best at what we do. **Give us a try today!**



COMPANY PROFILE	2
.....	
SQUARE DRIVE HYDRAULIC TORQUE TOOLS	3
.....	
LOW PROFILE HYDRAULIC TORQUE TOOLS	4
.....	
RAD PNEUMATIC TORQUE WRENCH	5
.....	
E-RAD ELECTRIC TORQUE WRENCH	6
.....	
B-RAD SELECT BATTERY WRENCH	7
.....	
TENSIONERS / PLATE HEAT EXCHANGER	8
.....	
FLANGE SPREADERS / VALVE IN VALVE OUT	9
.....	
FLANGE ALIGNMENT TOOLS & PINS	10
.....	
BACKUP WRENCHES / SOCKETS / MISC WRENCHES	11
.....	
CALIBRE & BOLT TESTING / MISSING LINK / IMPACTS	12
.....	
INDUCTION BOLT HEATING	13
.....	
TORQUE COMMAND CENTER	14
.....	
ON-SITE CALIBRATION	16
.....	
BOLTING TECHNICAL SERVICES	18



Square drive torque wrenches take on the toughest bolting jobs without missing a beat. They deliver precision torque during bolt makeup and maximum torque during bolt breakout.

They feature a compact design, constructed of aluminum and super high-strength steel alloy for increased strength and durability while minimizing the weight. The MaxDrv Series is available from 64 ft-lbs to 18,446 ft-lbs.

MaxDrv Series features:

- // Compact design/uni-body housing
- // Aluminum & steel alloy construction
- // 360° hose swivel assembly
- // 1 year warranty
- // Anti-jam torque release lever
- // Best in industry strength-to-weight ratio



MODEL	.7MD	1MD	3MD	5MD	10MD	20MD	35MD	50MD
Torque (ft-lbs)	64-793	125-1,318	270-3,030	538-5,480	1,050-11,206	2960-19760	3960-25890	7875-52500
Square Drive Size	.75"	.75"	1"	1.5"	1.5"	2.5"	2.5"	2.5"
Weight (lbs)	3.2	5	11	18	32	51.5	96	120
L1	3.90"	4.83"	6.18"	7.47"	9.36"	11.25"	13.914"	13.88"
L2	5.08"	6.23"	8.13"	9.73"	12.22"	17.5"	21.22"	23"
L3	3.32"	4.11"	5.31"	6.41"	3.95"	2.25"	3.216"	3.18"
H1	1.62"	1.97"	2.63"	3.16"	8.02"	4.733"	5.8"	6.56"
H2	2.56"	2.88"	3.72"	4.93"	5.75"	7.125"	8.615"	9.2"
H3	3.02"	3.77"	4.88"	5.97"	7.35"	8.813"	2.9"	11.5"
H4	4.29"	4.97"	6.46"	7.71"	9.04"	10.23"	12.36"	14.1"
W	1.5"	3.45"	4.49"	5.39"	6.73"	9.3"	9.9"	10.4"
R1	.83"	1.04"	1.31"	1.63"	2.03"	2.6"	2.9"	3.18"

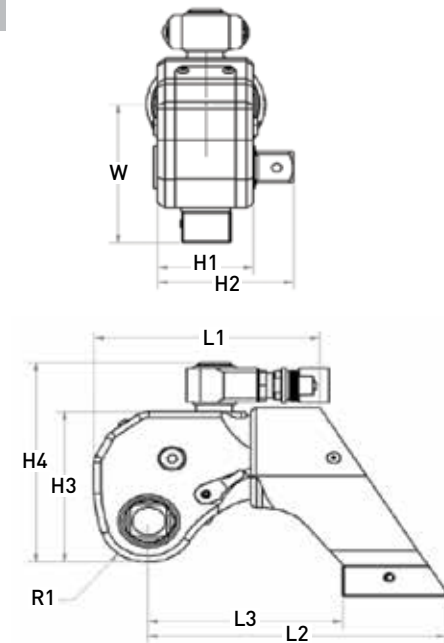

The versatile HexPro™ Series Hydraulic Torque Wrench supports an extensive range of interchangeable hexagon ratchet links that deliver a torque range of 150 ft-lbs to 30,000 ft-lbs. They deliver precision torque during bolt makeup and maximum torque during bolt breakout.

Ratchet Links are interchangeable with some other major brand tools.

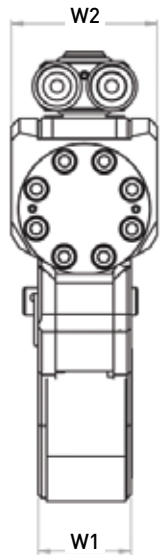

HexPro Series features

- // Compact design
- // 1-year warranty
- // 360° hose swivel assembly
- // Anti-jam torque release lever
- // Best in industry strength-to-weight ratio

Accessories

- // Alco arms // Reaction pads // Reducer bushings
- // Stack sockets // Back mount swivel

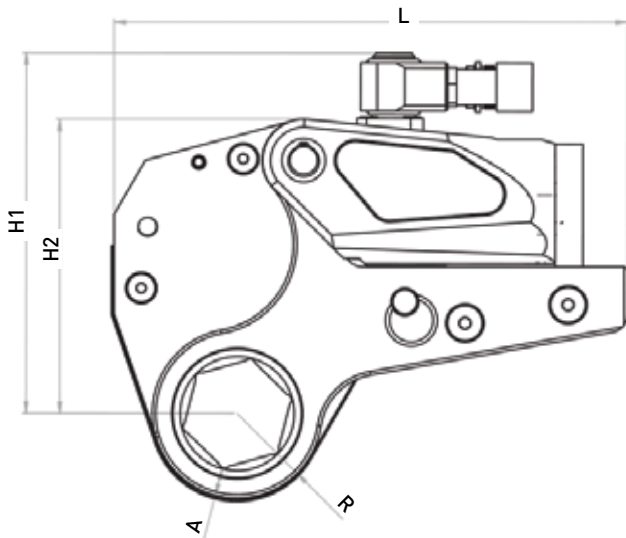

various reaction arms available

MODEL	2HP	4HP	8HP	14HP	30HP
Torque (ft-lbs)	162-1,714	439 - 4,500	762 - 8,100	1,245 - 13,443	3,050 - 28,861
Hex Size (imperial)	3/4"-2.3/8"	1.5/16"-3.1/8"	1.1/2"-3.15/16"	2"-4.5/8"	3.1/8"-6.7/8"
Power Head (lbs)	3	5	8	13	27
Ratchet Link (lbs)	4	9	16	26	70
A Dimension	.390"	.580"	.650"	.740"	1.010"
L	7.32"	9.72"	11.87"	14.24"	17.05"
H1	5.26"	7.85"	8.43"	9.41"	12.4"
H2	4.12"	5.71"	6.95"	8"	11.22"
W1	1.25"	1.65"	2.08"	2.52"	3.35"
W2	2"	2.6"	3.27"	3.88"	5.16"

- // Smooth continuous flow of controlled torque eliminating destructive hammering
- // Faster rundown on time sensitive bolting applications reaching speeds as high as 80 RPM
- // Controlled torque – accuracy of +/- 4% on target and repeatability of +/- 2%
- // No vibration
- // Under 80 dB



RAD PNEUMATIC TORQUE WRENCH

MODEL	350SL	7GX	10GX	15DX	25GX	30DX	34GX	50DX	60DX	80DX	85GX	110DX
Torque (ft-lbs)	50-350	100-700	200-1000	300-1500	500-2500	900-3000	1000-3400	1500-5000	2000-6000	2500-8000	3000-8500	4000-11,000
Drive Size	3/4"	3/4"	3/4"	1"	1"	1"	1"	1-1/2"	1-1/2"	1-1/2"	1-1/2"	1-1/2"

E-RAD ELECTRIC TORQUE WRENCH

E-RAD BLU series precision torque wrench tools are designed to provide a high degree of accuracy (+/- 3% on target) for high torque assembly applications. Our patented and extremely advanced electronic pistol grip torque wrench combines the legendary RAD gearbox design and AC Servo motor technology to reduce bolting time up to 300% as compared to conventional hydraulic wrenches.

This tool is capable of data collection and torque/angle measurement, ultimately offering an affordable solution for electronic bolting needs. It also includes a console module with a digital readout.



E-RAD BLU tool features:

- // Multiple models wrenches can be used in combination with one controller
- // Bluetooth connectivity with RAD Smart Socket for transducer verified joint calibration
- // Highly advanced Data Logging and Tool Management features
- // Military grade single cable and connector system
- // Available in 90 degree gearbox

MODEL	700	1500	2500 COMP	2500 COMP – 90 Degree	3000	6000	7500	11000
Torque (ft-lbs)	100-700	200-1500	250-2500	500-3000	1500-6000	1500-6000	1500-7500	3000-11000
Drive Size	3/4"	1"	1"	1"	1"	1.5"	1.5"	1.5"

Now With Digital Torque Settings And Torque Ranges Up To 3,000 Ft. Lbs!

The new B-RAD Select battery series torque wrenches come with two simple buttons to increase or decrease the value by 10 ft. lbs. At the four-digit display, the set torque value is displayed. The B-RAD select remembers the last set torque value even after the battery has been removed.

The B-RAD is especially suitable for pre-torque and service jobs where electricity or compressed air are not available.



MODEL	500	500-2	1000	1000-2	1500	1500-2	3000	3000-2
Torque (ft-lbs)	125-500	125-500	200-1000	200-1000	300-1500	300-1500	600-3000	600-3000
Drive Size	3/4"	3/4"	1"	1"	1"	1"	1"	1"

B-RAD SELECT BATTERY WRENCH

BOLT TENSIONERS



Hydraulic bolt tensioners available from 3/4" – 4-1/2" bolt sizes. Our massive inventory can handle any tensioning need.

Call [888.925.3284](tel:888.925.3284) or check out bustinyournuts.com for dimensions and sizes

PLATE HEAT EXCHANGER

We offer two methods of tooling for opening and closing of plate heat exchangers

- 1 6" stroke hydraulic rams with our backer plates squeeze the plate to desired crush in no time
- 2 Our offset pneumatic continuous nut runner will squeeze the plates even with the long bolts coming through



WE OFFER 24/7 - 365-DAY SERVICE

FLANGE SPREADER

Offset Hydraulic/Manual Flange Spreader

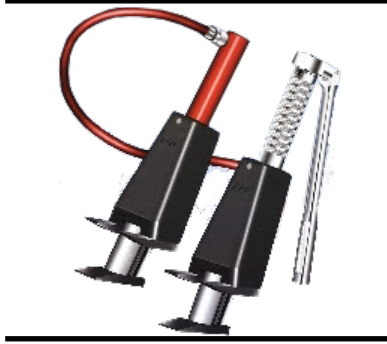

For flanges with no room.

Equalizer 14-Ton Mechanical Flange Spreader



Manual wrench included for operation. Comes in set of two for even flange spreading.

Equalizer 20-Ton Hydraulic Flange Spreader



Integrated hydraulic pump built into spreader. Comes in set of two for even flange spreading.

VALVE IN / OUT SPREADER



Our Valve In/Out Flange Spreader makes it possible for a flange to be spread from the outside diameter of the flange to enable a valve to be slipped in or out. This product eliminates the need of dangerous come-alongs, porta powers, and duck bill flange spreaders

Many different sizes are available with spacers to extend for all different size valves.

FLANGE ALIGNMENT TOOLS

FA4TM Mechanical linear & rotational flange alignment tool

A simple solution to medium diameter, medium pressure flange joint misalignment

- // Compact lightweight design - 19 lbs
- // 4T (40kN) aligning force
- // Comes with securing strap



FA9TE Hydraulic linear & rotational alignment tool

A simple solution to large diameter high pressure flange joint misalignment

- // Compact lightweight design - 32 lbs
- // 9T (90kN) aligning force
- // Comes with securing strap
- // Can also be used on rotational misalignment
- // Comes with 10,000 psi hydraulic hand pump



ALIGNMENT PINS

Flange alignment pins will help align any flange manually. Most rent or purchase the pins in sets of 2 for even alignment.

The pins are measured by the BOLT HOLE SIZE, not the BOLT SIZE. Please refer to the chart below and call for availability.



FLANGE ALIGNING TOOL - EXTRA LONG

CATALOG NO.	BOLT HOLE SIZE	LENGTH	WEIGHT
FT0L	1/2"	5-3/8"	5 oz
FT01L	5/8"	5-3/4"	8 oz
FT02L	3/4"	6-1/4"	14 oz
FT03L	7/8"	6-1/2"	1-1/8 lbs
FT04L	1"	7"	1-1/2 lbs
FT06L	1-1/8"	8"	2-1/4 lbs
FT08L	1-1/4"	8-1/2"	3 lbs
FT1012L	1-3/8"	9-1/4"	4 lbs
FT14L	1-1/2"	9-1/2"	4-5/8 lbs

FT16L	1-5/8"	10-1/4"	5-3/4 lbs
FT1820L	1-3/4"	10-7/8"	6-5/8 lbs
FT22L	1-7/8"	11-3/8"	8-1/8 lbs
FT2426L	2"	12"	9-1/4 lbs
FT30L	2-1/8"	15"	13-1/2 lbs
FT34L	2-3/8"	16-1/4"	17-1/4 lbs
FT3642L	2-5/8"	17"	21 lbs
FT3642XL	2-5/8"	22"	28-7/8 lbs

BACKUP WRENCHES

Piper backup by Muskegon



The Piper backup wrench rests on the flange and when done torquing the nut on opposite side of the flange, you simply release by a few hits of a hammer.

Lokrites



- // Lokrite boxend style wrench
- // Lokrite open end style wrench
- // For all of your standard bolting applications
- // Pinch-point free
- // Hands-free

Load Release Backup Wrenches



After tightening the nut on the other side, this backup can be taken off by simply loosening the bolt and releasing the backup wrench.



SOCKETS

Industrial Bolting has the largest selection of in-stock sockets for rental or sale: 1/2" drive up to 3-1/2" drive.

We offer standard and deep well along with metric and standard sizes. Also, have many custom stack sockets for unique applications, and stock drive reducers and adapters.

3/4" Drive Offset Crowsfeet



Hard to find 3/4" drive thin wall crowsfeet. For applications where the nut is too close to the pipe. 1-1/16" - 2-3/8" available.

MISC WRENCHES

Offset Slugging Wrenches



Straight Slugging Wrenches



CALIBRE AND BOLT TESTING



- // Bolt load tester
- // 5/8" - 2" bolt diameters
- // Steel bridge construction
- // Steel beam construction
- // Wind turbine tower bolt tester

MISSING LINK



The Norwolf Missing Link™ torque multiplier fits into tightly confined areas where sockets will not fit. The Missing Link has become standard in the wind industry for generator feet and yaw pucks.



IMPACTS

We offer a various range of impact wrenches for sale or rent.

- // 1/2" drive impacts
- // 3/4" drive impacts
- // 1" drive impacts
- // 1-1/2" drive impacts
- // 2-1/2" drive impact
- // 90-degree impacts





We offer on-site Induction Bolt Heating service

Bolt elongation of: // Turbine bolts // Boiler feed pump bolts // Stop valve bolts // Throttle valve bolts // Refinery heat exchanger nuts

Induction heating drastically reduces the time it takes to heat stretch the bolt to elongate it enough to loosen/tighten the nut.

Our machines are so small yet powerful, we do not need a crane to lift to the turbine deck, forklifts to pull out of a trailer or 6 millwrights tied up for 5 hours getting equipment set up. We can roll our machines out of our trailer, put them in any passenger elevator and up to the turbine deck in 20 minutes.



- // **Trained bolting technicians**
- // **Mobile torque/tension warehouse**
- // **Customized tooling for the bolting scope**



At Industrial Bolting, we have customized tool trailers with a technical assistants fully loaded with all the torque/tension tooling needed for the scope of your turnaround. We walk the job with you or your contractor to ensure that the proper amount of torque tools and the proper style of torque tools are supplied for the job.

Minor repairs, technical assistance are all performed on-site by the technician in the Torque Command Center to make the job run smooth and on time.



TORQUE COMMAND CENTER



WE COME TO YOU!

We realize that when your tools are down, then work is not getting done. Shipping tools out to get recalibrated and worked on takes time and costs you lost revenue. Industrial Bolting has a mobile repair shop and calibration center. We come to you! We repair and calibrate pneumatic and hydraulic torque wrenches. This helps eliminate: *downtime, being without your tools for any length of time and shipping cost.*

Contact us immediately for our mobile **On-Site Calibration** center to come to your jobsite

888.925.3284



ON-SITE CALIBRATION

BOLTING TECHNICAL SERVICES



Whether it is an on-site technical adviser you need while renting our bolting tools or it is a project that you need someone to simply come and do, Industrial Bolting will provide professional technicians to work with your crew to get the job done correctly and safely.

If you are just wanting the bolting job completed, we can come in and bust the bolts/re-torque the bolts for you.

Contact us at 888-925-3284!





Contact us immediately for **Bolting Technical Services** to come to your jobsite

888.925.3284

BOLTING TECHNICAL SERVICES

Contact us 24/7 for the best torque and tension products that can be delivered to your jobsite!

888.925.3284

Central Indiana 317.896.4381

NW Indiana 219.616.6144

Louisville, KY / Southern Indiana 812.201.7171

Chicagoland / N. Illinois 815.342.8611

Ohio / Western PA 614.302.5262

Minnesota 888.925.3284

Iowa / Missouri / Nebraska 765.307.0049

Central Southern Illinois 812.259.0286

bustinyournuts.com

